

# **BUNN**®

## *Soft Heat*® *Server*

1.50 & 1.75 Gallon

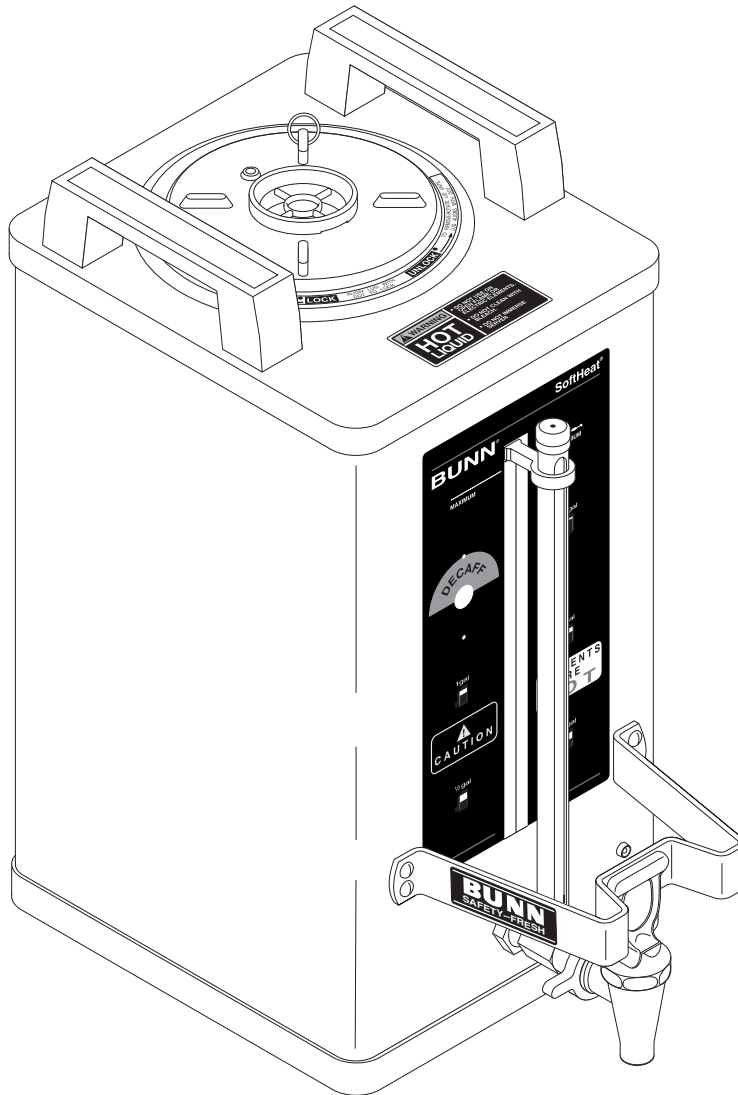

## **ILLUSTRATED PARTS CATALOG**

Designs, materials, weights, specifications, and dimensions for equipment or replacement parts are subject to change without notice.

**BUNN-O-MATIC CORPORATION**

POST OFFICE BOX 3227

SPRINGFIELD, ILLINOIS 62708-3227

PHONE: (217) 529-6601 FAX: (217) 529-6644

## **BUNN-O-MATIC COMMERCIAL PRODUCT WARRANTY**

Bunn-O-Matic Corp. ("BUNN") warrants equipment manufactured by it as follows:

- 1) All equipment other than as specified below: 2 years parts and 1 year labor.
- 2) Electronic circuit and/or control boards: parts and labor for 3 years.
- 3) Compressors on refrigeration equipment: 5 years parts and 1 year labor.
- 4) Grinding burrs on coffee grinding equipment to grind coffee to meet original factory screen sieve analysis: parts and labor for 3 years or 30,000 pounds of coffee, whichever comes first.

These warranty periods run from the date of installation. BUNN warrants that the equipment manufactured by it will be commercially free of defects in material and workmanship existing at the time of manufacture and appearing within the applicable warranty period. This warranty does not apply to any equipment, component or part that was not manufactured by BUNN or that, in BUNN's judgment, has been affected by misuse, neglect, alteration, improper installation or operation, improper maintenance or repair, damage or casualty. This warranty is conditioned on the Buyer 1) giving BUNN prompt notice of any claim to be made under this warranty by telephone at (217) 529-6601 or by writing to Post Office Box 3227, Springfield, Illinois 62708-3227; 2) if requested by BUNN, shipping the defective equipment prepaid to an authorized BUNN service location; and 3) receiving prior authorization from BUNN that the defective equipment is under warranty.

**THE FOREGOING WARRANTY IS EXCLUSIVE AND IS IN LIEU OF ANY OTHER WARRANTY, WRITTEN OR ORAL, EXPRESS OR IMPLIED, INCLUDING, BUT NOT LIMITED TO, ANY IMPLIED WARRANTY OF EITHER MERCHANTABILITY OR FITNESS FOR A PARTICULAR PURPOSE.** The agents, dealers or employees of BUNN are not authorized to make modifications to this warranty or to make additional warranties that are binding on BUNN. Accordingly, statements by such individuals, whether oral or written, do not constitute warranties and should not be relied upon.

If BUNN determines in its sole discretion that the equipment does not conform to the warranty, BUNN, at its exclusive option while the equipment is under warranty, shall either 1) provide at no charge replacement parts and/or labor (during the applicable parts and labor warranty periods specified above) to repair the defective components, provided that this repair is done by a BUNN Authorized Service Representative; or 2) shall replace the equipment or refund the purchase price for the equipment.

**THE BUYER'S REMEDY AGAINST BUNN FOR THE BREACH OF ANY OBLIGATION ARISING OUT OF THE SALE OF THIS EQUIPMENT, WHETHER DERIVED FROM WARRANTY OR OTHERWISE, SHALL BE LIMITED, AT BUNN'S SOLE OPTION AS SPECIFIED HEREIN, TO REPAIR, REPLACEMENT OR REFUND.**

In no event shall BUNN be liable for any other damage or loss, including, but not limited to, lost profits, lost sales, loss of use of equipment, claims of Buyer's customers, cost of capital, cost of down time, cost of substitute equipment, facilities or services, or any other special, incidental or consequential damages.

# TABLE OF CONTENTS

Covers, Handles and Guard.....	4
Electrical Components .....	10
Faucet and Sight Gauge .....	8
Lid Assembly .....	6
Numerical Index.....	12

Torque to 22 in. lbs.

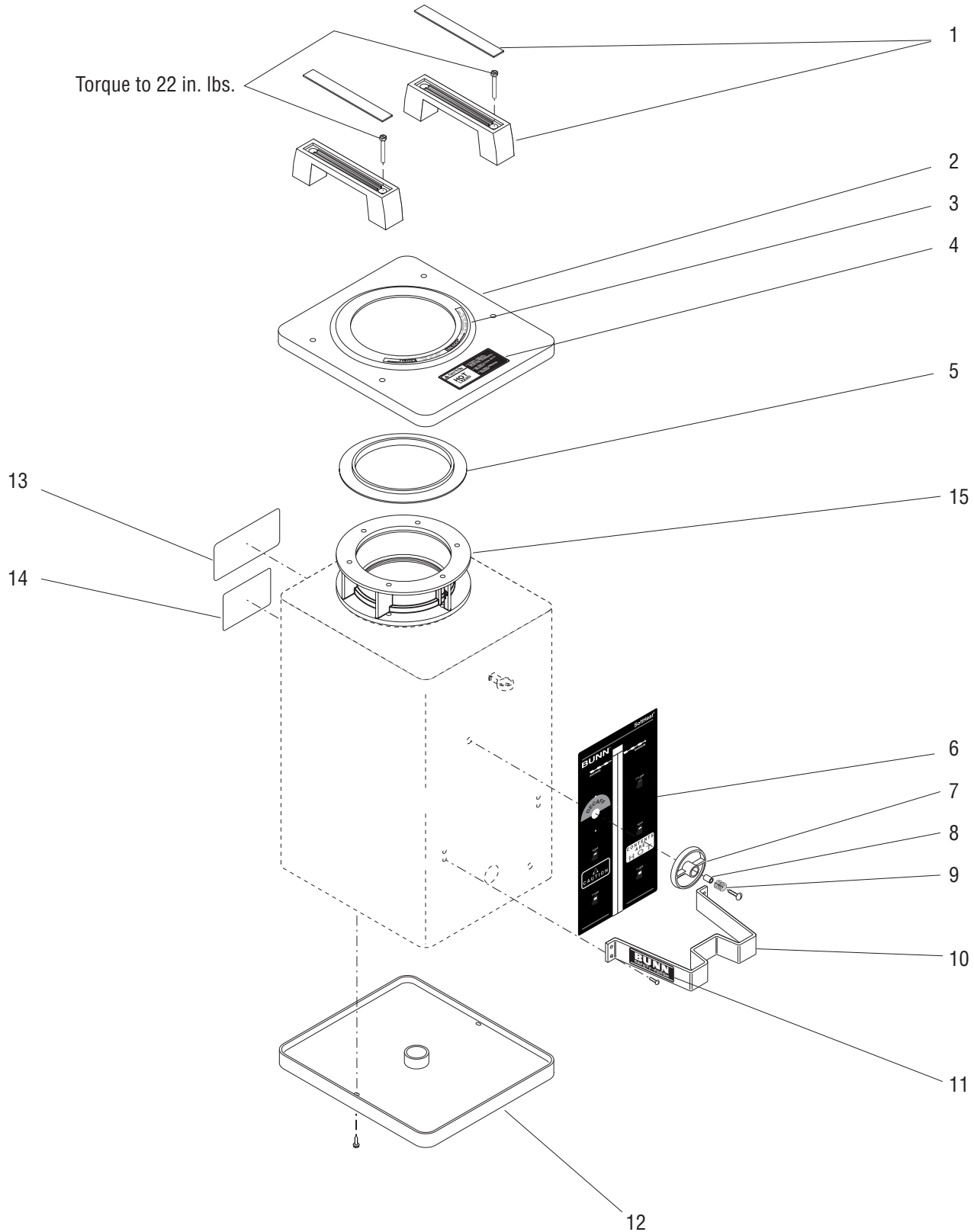

## COVERS, HANDLES AND GUARD

ITEM	PART NO.	QTY.	DESCRIPTION
1	26181.0000	2	Handle, Top
	02359.0001	4	Screw, Hex Head 10 - 32 x 1.25"
2	26187.0000	1	Cover W/Decal, Top (Includes items 3 & 4)
3	26803.0000	1	Decal, Lock - Unlock
4	26186.0000	1	Decal, Caution - Hot Liquid
5	25872.0000	1	Gasket, Top Cover
6	28159.0000	1	Decal, Decorative W/Level Indicators (1.50 Gallon Server)
	26178.0001	1	Decal, Decorative W/Level Indicators (1.75 Gallon Server)
7	27531.0000	1	Indicator Disk
	27555.0001	1	Screw, Binding Head BLK #8-32 x .625"
8	27525.0000	1	Spacer, Nylon
9	27554.0000	1	Spring
10	-----	1	Faucet Guard W/Decals SST (Includes item 11)(Not available. Order Black Guard)
	21939.0000	1	Faucet Guard W/Decals BLK (Includes item 11)
	20753.1004	1	Faucet Guard W/Decals RED (Includes item 11)
	-----	4	Screw, Truss Head 8 - 32 x .375" (Early Servers)
	02329.0002	4	Screw, Rd Head 8 - 32 x .312" BLK (Late Servers)
11	20968.0000	2	Decal, Safety Fresh
12	25880.0000	1	Trim Ring, Bottom
	02328.0000	2	Screw, Pan Head 6 - 32 x .375" Locking
13	28151.0000	1	Decal, Do Not Immerse Server
14	28056.0000	1	Decal, SH Server Use
15	25951.1000	1	Collar Spacer Kit

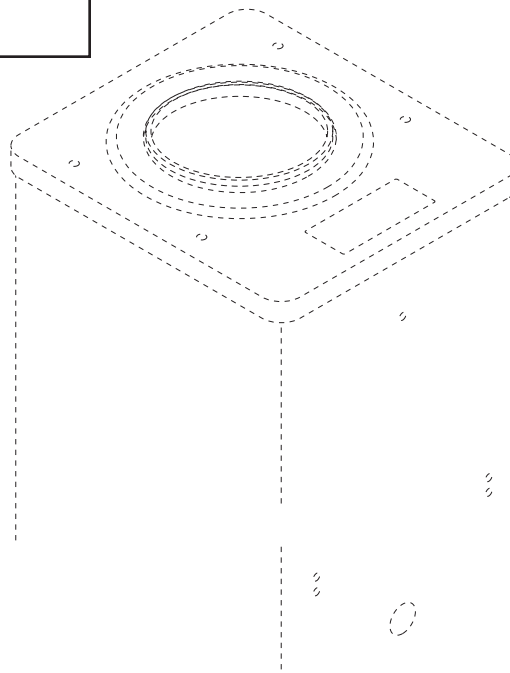
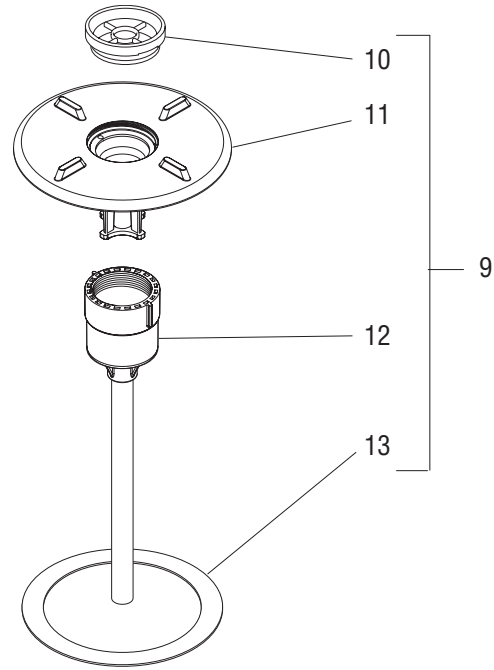
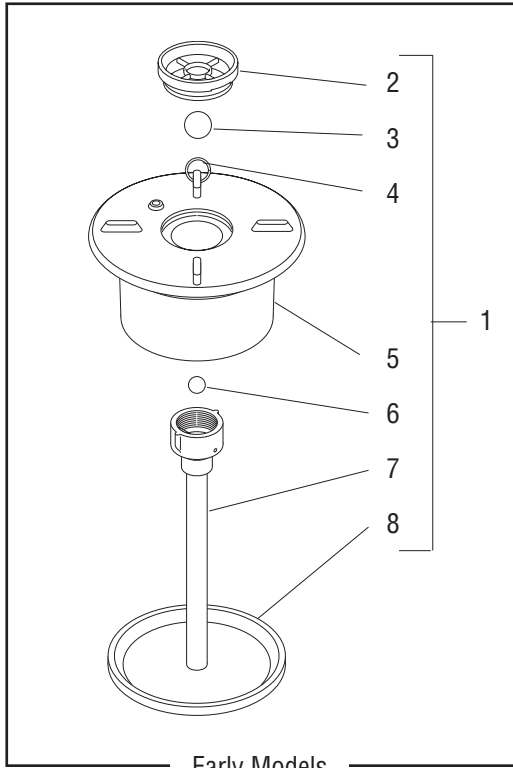

## LID ASSEMBLY

ITEM	PART NO.	QTY.	DESCRIPTION
1	25871.1001	1	Lid Assembly (Early Models)(Includes items 2 thru 7)
2	12289.0001	1	Retainer Cap, Top
3	12327.0000	1	Ball (Early Models only)
4	26361.0000	1	Split Ring
5	-----	1	Lid Assy, Reservoir (Order item 1)
6	00598.0002	1	Ball, .50"
7	25875.0000	1	Tube Assy, Inlet
8	25952.0000	1	Seal, Top Cover
9	29690.1004	1	Lid Assembly (Late Models)(Includes items 10 thru 13)
10	12289.0001	1	Retainer Cap, Top
11	29690.0004	1	Lid Assy, Reservoir
12	38041.0000	1	Tube Assy, Inlet
13	12332.0000	1	Gasket

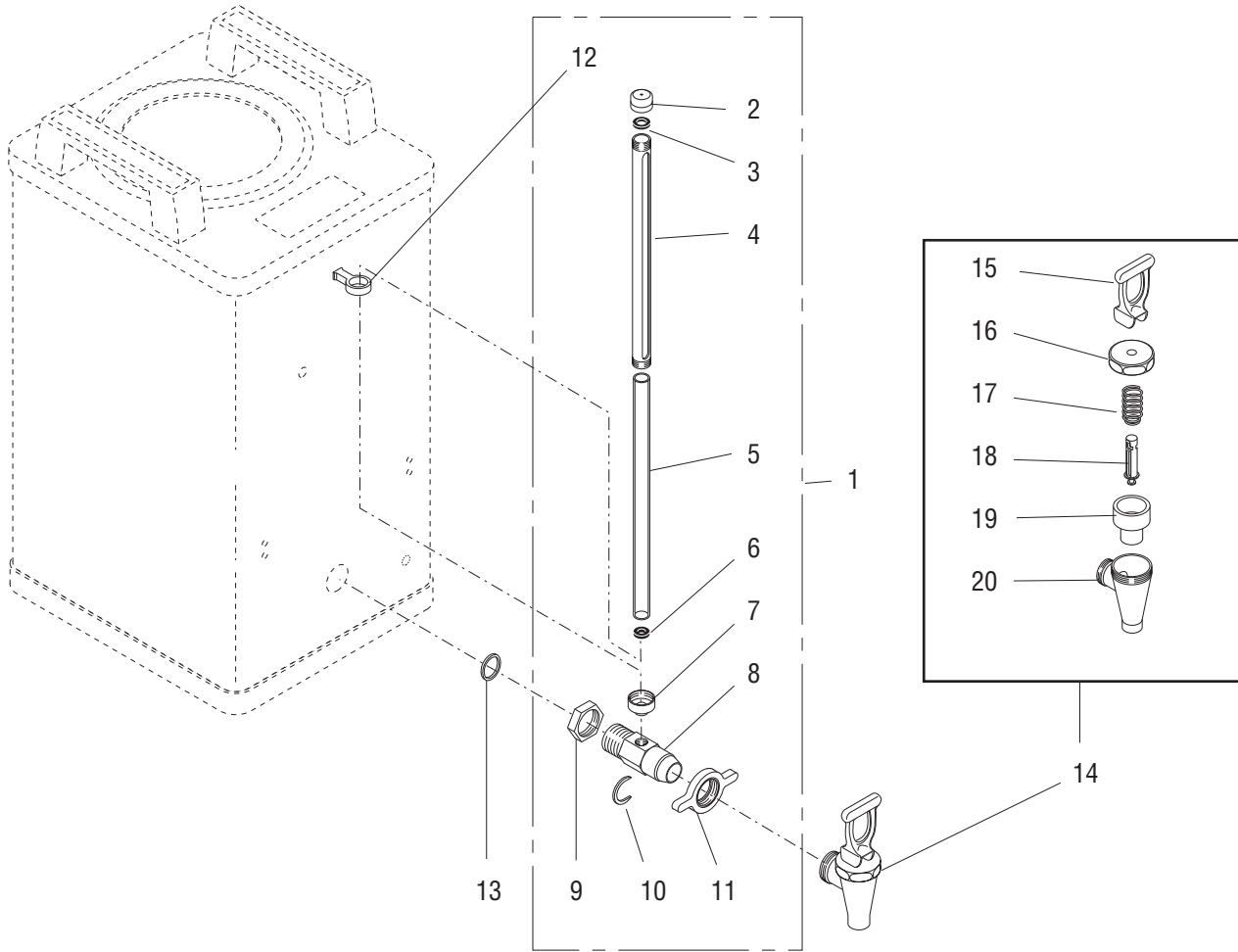

## FAUCET AND SIGHT GAUGE

ITEM	PART NO.	QTY.	DESCRIPTION
1	26688.0003	1	Faucet Shank Assy W/Sight Gauge (Plastic Faucet)(Includes items 2 thru 12)
	26688.0004	1	Faucet Shank Assy W/Sight Gauge (Chrome Faucet)(Includes items 2 thru 12)
2	01293.0000	1	Vent Cap, Sight Gauge
3	01291.0000	1	Washer, Vent Cap
4	26687.0002	1	Sheild, Sight Gauge
5	26686.0002	1	Sight Gauge Glass
6	01292.0000	1	Washer, Sight Gauge Base
7	01222.0000	1	Base, Sight Gauge
8	01261.0002	1	Shank, Faucet (Includes items 9, 10 & 11)
9	20761.0000	1	Nut, Faucet Shank
10	01221.0000	1	C-Ring, Faucet Shank
11	03093.0002	1	Faucet Nut, Wing Type
12	01287.0000	1	Brace, Sheild
13	20756.0000	1	Gasket, Faucet Shank
14	26685.0000	1	Faucet Assy, Black Handle (Includes items 15 thru 20)
15	26684.0000	1	Faucet Handle, Black
16	29165.0001	1	Faucet Bonnet (Not available. Order item 14)
17	00601.0000	1	Faucet Spring
18	29164.0000	1	Faucet Stem (Not available. Order item 14)
19	00600.0000	1	Faucet Seat Cup
20	-----	1	Faucet Body (Not available. Order item 14)
21	00674.0000	-	Brush, Faucet Shank Cleaning .75" O.D.
22	00675.0000	-	Brush, Sight Gauge Cleaning .50" O.D.
23	26367.0000	-	Brush, Vent Cleaning .25" O.D.
24	28709.0000	-	Faucet Repair Kit, Blk (Includes items 15, 17, 18 & 19)

} Not illustrated

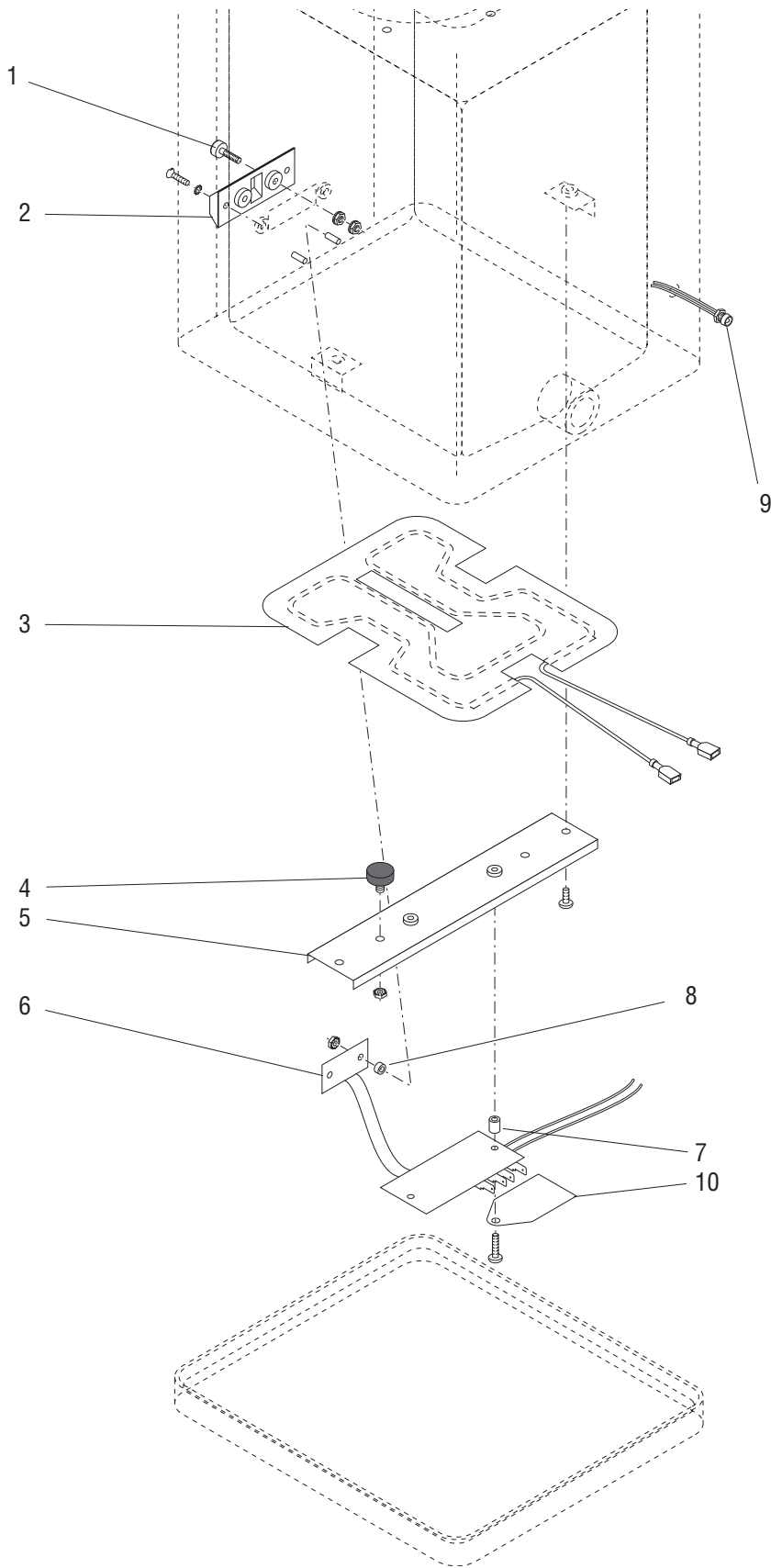

## ELECTRICAL COMPONENTS

ITEM	PART NO.	QTY.	DESCRIPTION
1	27749.0000	2	Terminal, Contact
	00973.0001	4	Nut, Keps #6-32
2	27745.0000	1	Housing, Contact Pad
	01345.0000	2	Screw, Flat Head #6-32 x .50"
	01511.0000	2	Lockwasher, External Tooth #8
3	27787.0001	1	Heater, Blanket
4	25137.0002	2	Foot, Black Rubber .75" O.D.
	00970.0000	2	Nut, Keps #8-32 Zinc Pl
5	27795.0000	1	Channel, Tank Support
	02308.0000	2	Screw, Pan Head Serrated #8-32 x .38"
6	27792.1000	1	Circuit Board Assembly (1.75 Gallon Server)(Includes item 11)
	38714.1001	1	Circuit Board Assembly (1.75 Gallon Server)(RoHS Compliant for European use)
	27792.1001	1	Circuit Board Assembly, Adjustable (1.5 Gallon Server)(Includes item 10 & 11)
	38714.1000	1	Circuit Board Assembly (1.5 Gallon Server)(RoHS Compliant for European use)
	02367.0002	2	Screw, Truss Head Locking #6-32 x .625"
	00973.0001	2	Nut, Keps #6-32 Zinc Pl
7	01533.0000	2	Spacer, Nylon .375" LG
8	01533.0007	2	Spacer, Nylon .125" LG
9	12516.1005	1	Lamp Assembly W/Leads (Includes item 11)
10	27747.0000	1	Tag, Adjustable Circuit Board Timer Setting
11	27796.0000	2	UR Connector, RED 19-26 AWG
12	21016.0114	1	Lead, Electrical Red 10" LG (Contact Terminal to Circuit Board)
13	21016.0121	1	Lead, Electrical Black 10" LG (Contact Terminal to Circuit Board)
14	00617.0000	1	Tie, Cable 3.9" LG

} Not Illustrated

# NUMERICAL INDEX

PART NO.	PAGE NO.	PART NO.	PAGE NO.	PART NO.	PAGE NO.	PART NO.	PAGE NO.
00598.0002.....	7	26688.0003.....	9				
00600.0000.....	9	26688.0004.....	9				
00601.0000.....	9	26803.0000.....	5				
00617.0000.....	11	27525.0000.....	5				
00674.0000.....	9	27531.0000.....	5				
00675.0000.....	9	27554.0000.....	5				
00970.0000.....	11	27555.0001.....	5				
00973.0001.....	11	27745.0000.....	11				
01221.0000.....	9	27747.0000.....	11				
01222.0000.....	9	27749.0000.....	11				
01261.0002.....	9	27787.0001.....	11				
01287.0000.....	9	27792.1000.....	11				
01291.0000.....	9	27792.1001.....	11				
01292.0000.....	9	27795.0000.....	11				
01293.0000.....	9	27796.0000.....	11				
01345.0000.....	11	28056.0000.....	5				
01511.0000.....	11	28151.0000.....	5				
01533.0000.....	11	28159.0000.....	5				
01533.0007.....	11	28709.0000.....	9				
02308.0000.....	11	29164.0000.....	9				
02328.0000.....	5	29165.0001.....	9				
02329.0002.....	5	29690.0004.....	7				
02359.0001.....	5	29690.1004.....	7				
02367.0002.....	11	38041.0000.....	7				
03093.0002.....	9	38714.1000.....	11				
12289.0001.....	7	38714.1001.....	11				
12327.0000.....	7						
12332.0000.....	7						
12516.1005.....	11						
20753.1004.....	5						
20756.0000.....	9						
20761.0000.....	9						
20968.0000.....	5						
21016.0114.....	11						
21016.0121.....	11						
21939.0000.....	5						
25137.0002.....	11						
25871.1001.....	7						
25872.0000.....	5						
25875.0000.....	7						
25880.0000.....	5						
25951.1000.....	5						
25952.0000.....	7						
26178.0001.....	5						
26181.0000.....	5						
26186.0000.....	5						
26187.0000.....	5						
26361.0000.....	7						
26367.0000.....	9						
26684.0000.....	9						
26685.0000.....	9						
26686.0002.....	9						
26687.0002.....	9						